Техническое описание продукта DECOSTAR 51 ALU 50 W 12 V 36° GU5.3

DECOSTAR 51 ALU | Рефлекторные галогенные лампы с алюминиевым отражателем диаметром 51мм

- General illumination Shops Restaurants, hotels and similar prestigious applications Offices, public buildings



- Brilliant accent light No light can escape at the back of the reflector Approved for use in open luminaires (to IEC 60598-1) UV filter Aluminum-coated reflector without a shield reduces thermal load in luminaire Reduced thermal load: ~60 % compared with aluminum-coated reflectors with shield Reduced thermal load: ~80 % compared with dichroic reflectors with shield



Техническое описание продукта

Technical data

Фотометрические данные

ZLDV_Nominal useful luminous flux 90° [AGGR]	680 lm
ZLDV_Luminous intensity [AGGR]	1800 cd
ZLDV_Light color (designation) [AGGR]	Warm White
ZLDV_Rated peak intensity [AGGR]	1800 cd
ZLDV_Luminous flux [AGGR]	680 lm

Светотехнические параметры

ZLDV_Beam angle [AGGR]	36 °
ZLDV_Rated beam angle (half peak value) [AGGR]	36.00 °

Размеры и вес

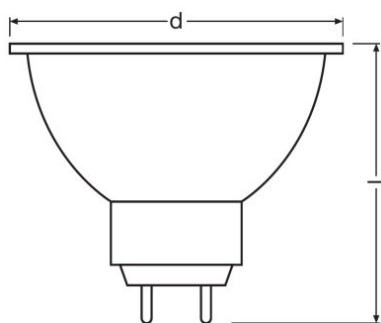

ZLDV_Overall length [AGGR]	46.00 mm
ZLDV_Product weight [AGGR]	24.05 g
ZLDV_Maximum diameter [AGGR]	51 mm

Дополнительные данные

ZLDV_Mercury content [AGGR]	0.0 mg
ZLDV_Mercury-free [AGGR]	Yes

Возможности / мощности

ZLDV_Burning position [AGGR]	Any
------------------------------	-----

Сертификаты и Стандарты

ZLDV_Energy efficiency class [AGGR]	G
ZLDV_Energy consumption [AGGR]	54.00 kWh/1000h

Техническое описание продукта

Классификация

ZLDV_ILCOS [AGGR]	HAGS//UB-50-12-GU5.3-51/36
-------------------	----------------------------

Environmental information

Information according Art. 33 of EU Regulation (EC) 1907/2006 (REACH)	
Date of Declaration	18-04-2022
Primary Article Identifier	4050300428857
Declaration No. in SCIP database	In work

Распределение силы света

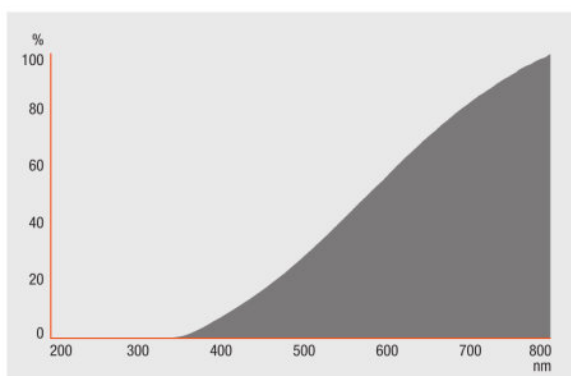

HAL_NV_UVS

Ecodesign regulation information:

Separate control gear and light sources must be disposed of at certified disposal companies in accordance with Directive 2012/19/EU (WEEE) in the EU and with Waste Electrical and Electronic Equipment (WEEE) Regulations 2013 in the UK. For this purpose, collection points for recycling centres and take-back systems (CRSO) are available from retailers or private disposal companies, which accept separate control gear and light sources free of charge. In this way, raw materials are conserved and materials are recycled.

Данные для заказа

Техническое описание продукта

Product code	Описание продукта	Упаковка (цена/шт.)	Размеры (длина x ширина x высота)	Объем	Вес брутто
4050300428857	DECOSTAR 51 ALU 50 W 12 V 36° GU5.3	Shipping carton box 20 шт. Folding carton box	172 mm x 122 mm x 174 mm	3.65 дм ³	690.00 g

The mentioned product code describes the smallest quantity unit which can be ordered. One shipping unit can contain one or more single products. When placing an order, for the quantity please enter single or multiples of a shipping unit.

Примечание

Subject to change without notice. Errors and omission excepted. Always make sure to use the most recent release.

OSRAM is distribution partner
of LEDVANCE of LAMPS

OSRAM

OSRAM GmbH
Marcel-Breuer-Strasse 6
80807 Munich, Germany