

4 062 50/52/56 4 062 58/60/62 4 062 64 4 062 66 4 062 76/78 4 062 80/82 4 062 84 4 062 85 4 062 86 4 062 87

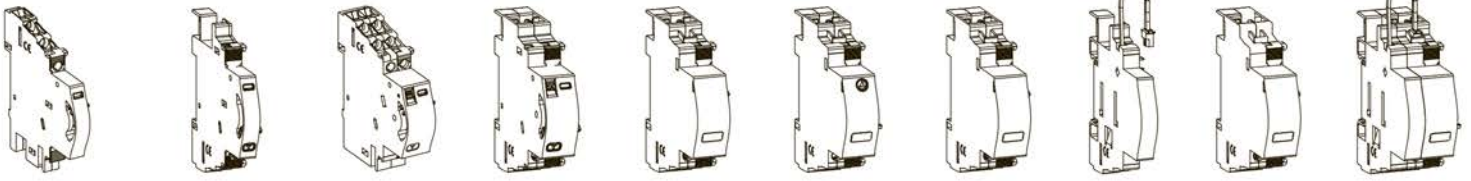

CA

4 062 50/58

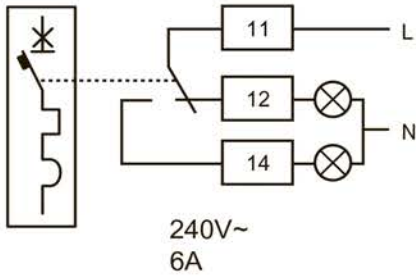
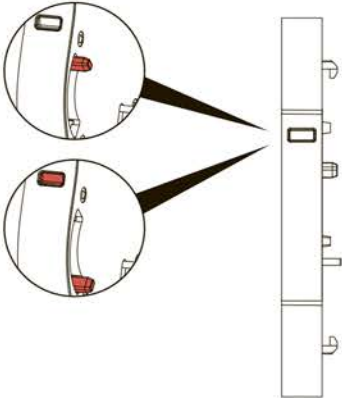

SD

4 062 52/60

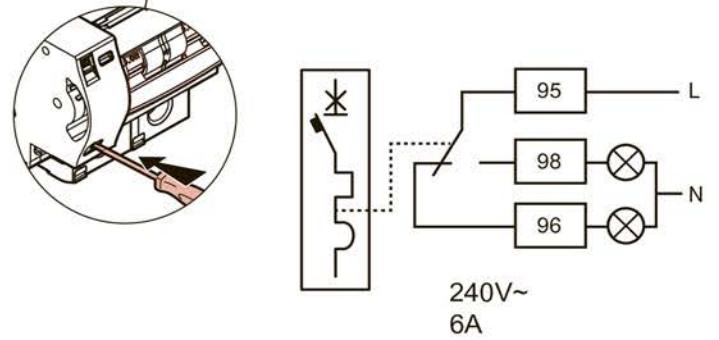
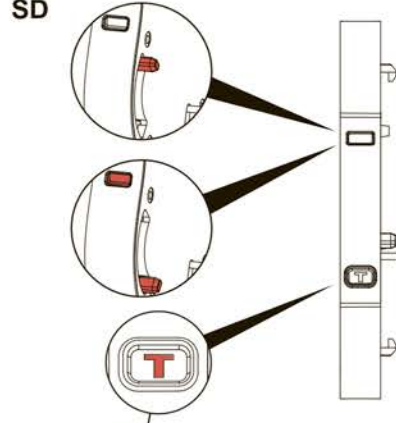

CA/SD

4 062 56/62

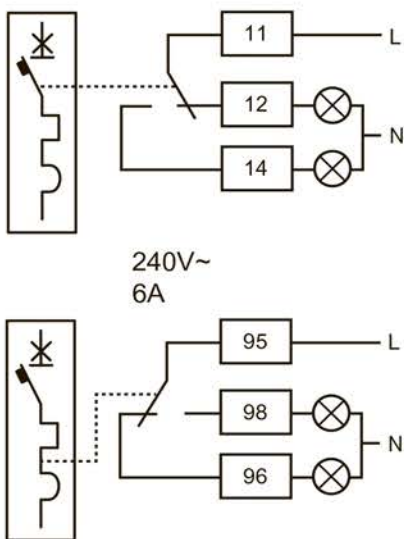
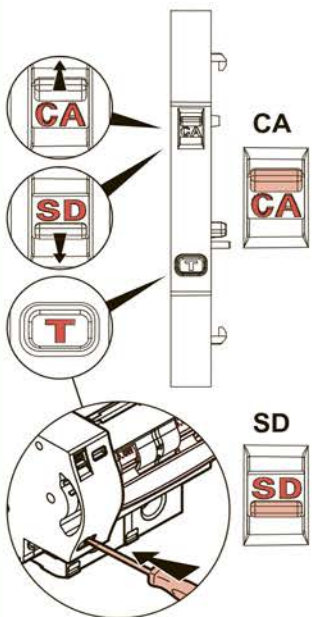

CA+SD
CA+CA

4 062 64/66

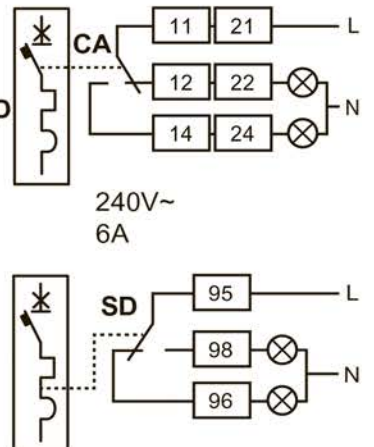
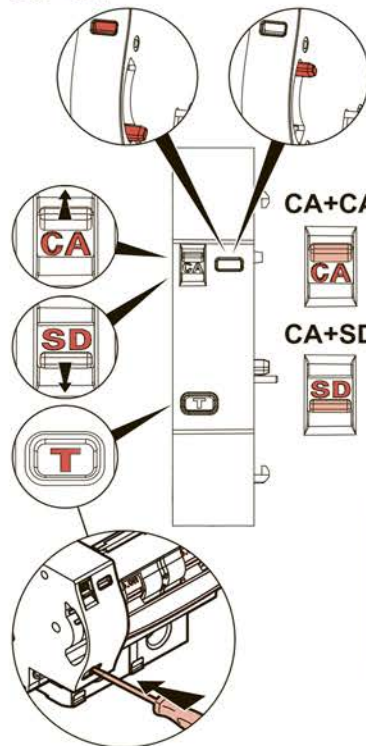

ET

4 062 76
4 062 78

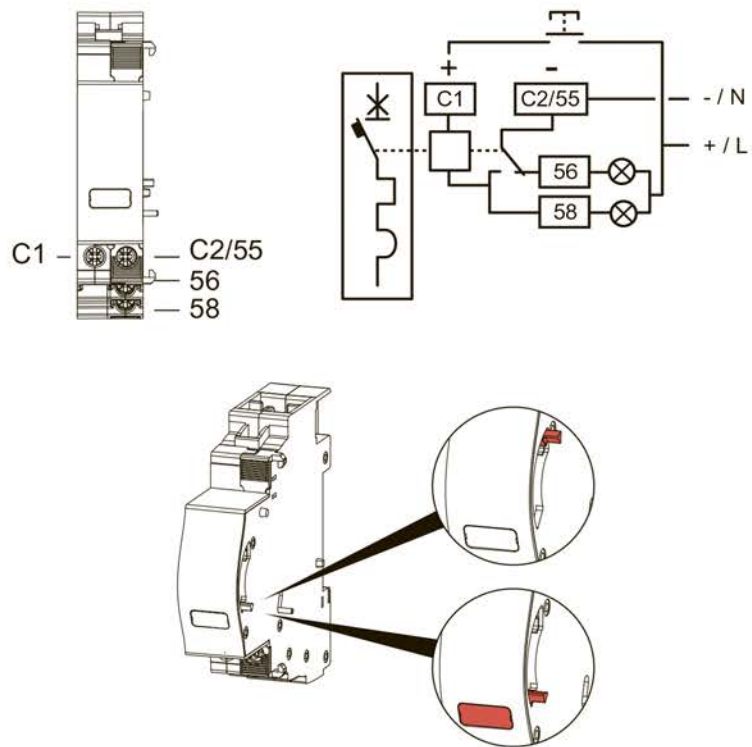

POP

4 062 86

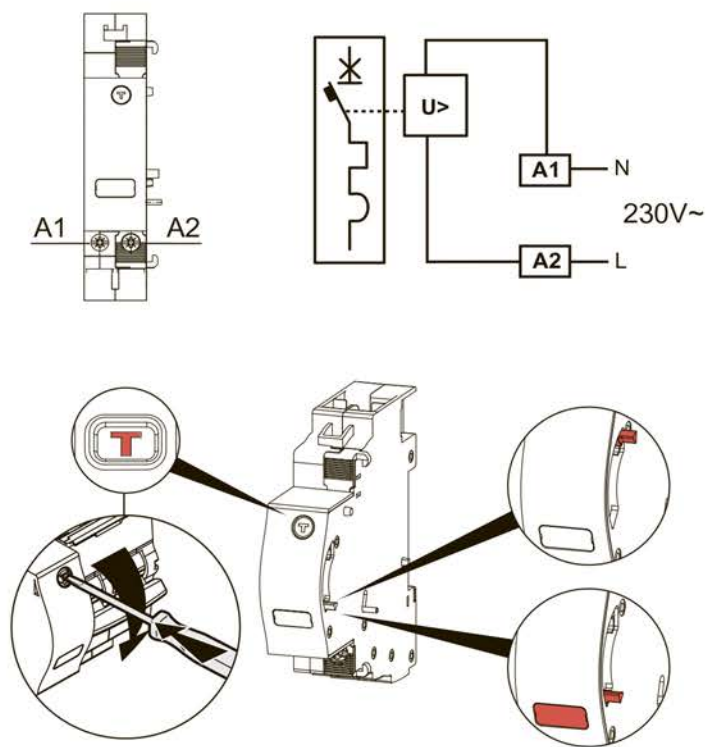

MT

4 062 80

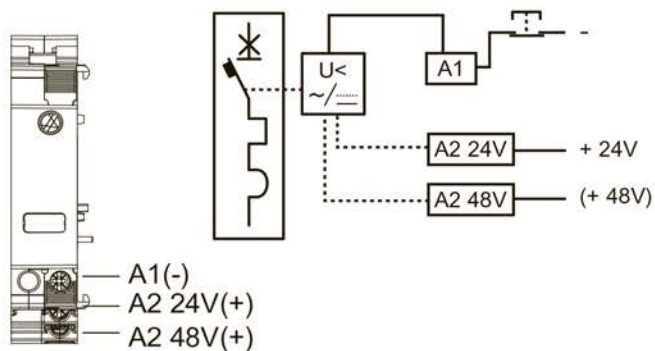

DA

4 062 84
4 062 85
4 062 87

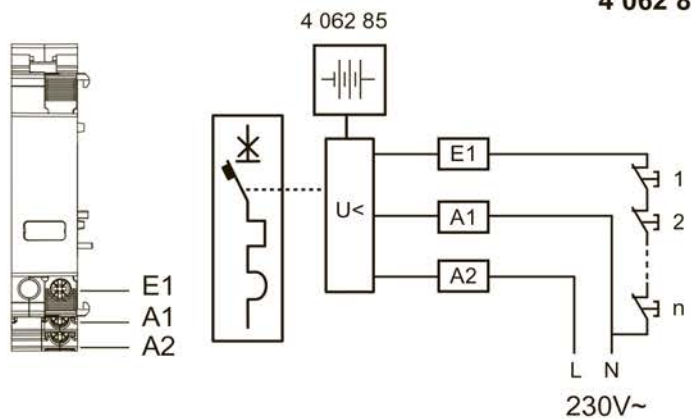

4 062 82

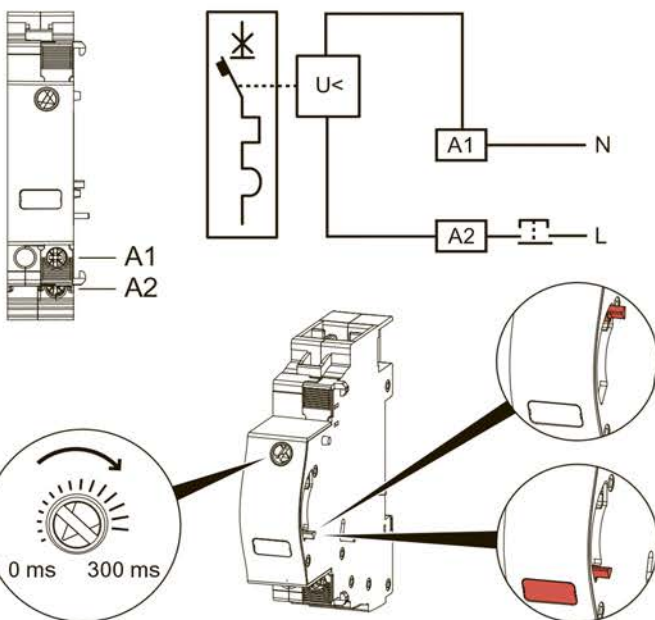

4 062 85

4 062 84

4 062 87

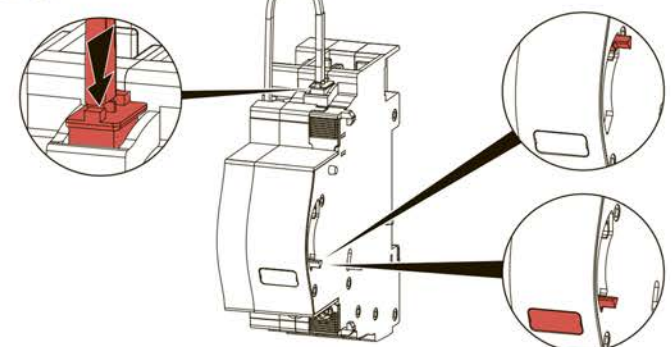

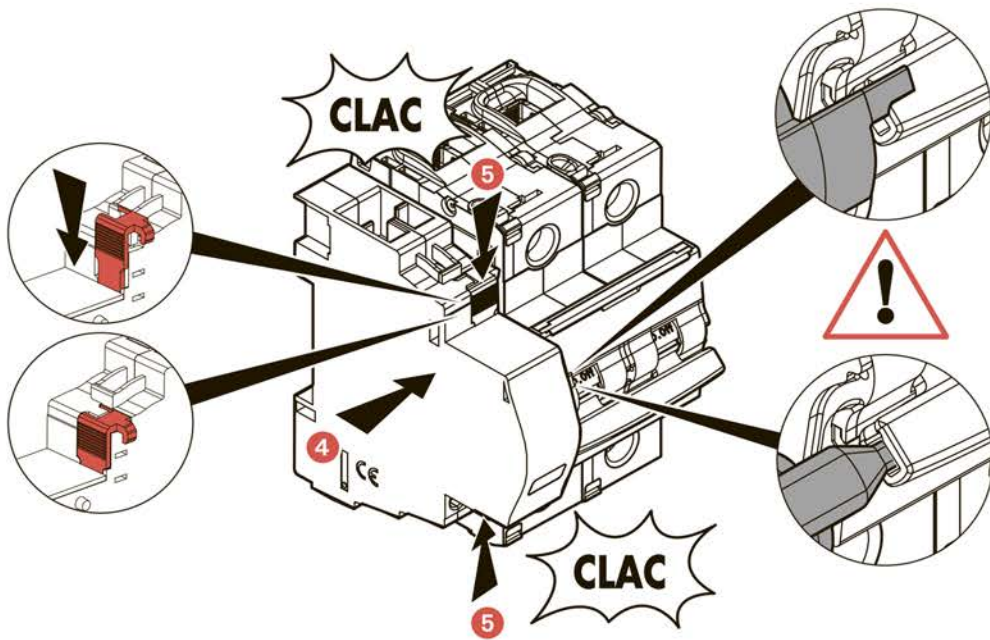
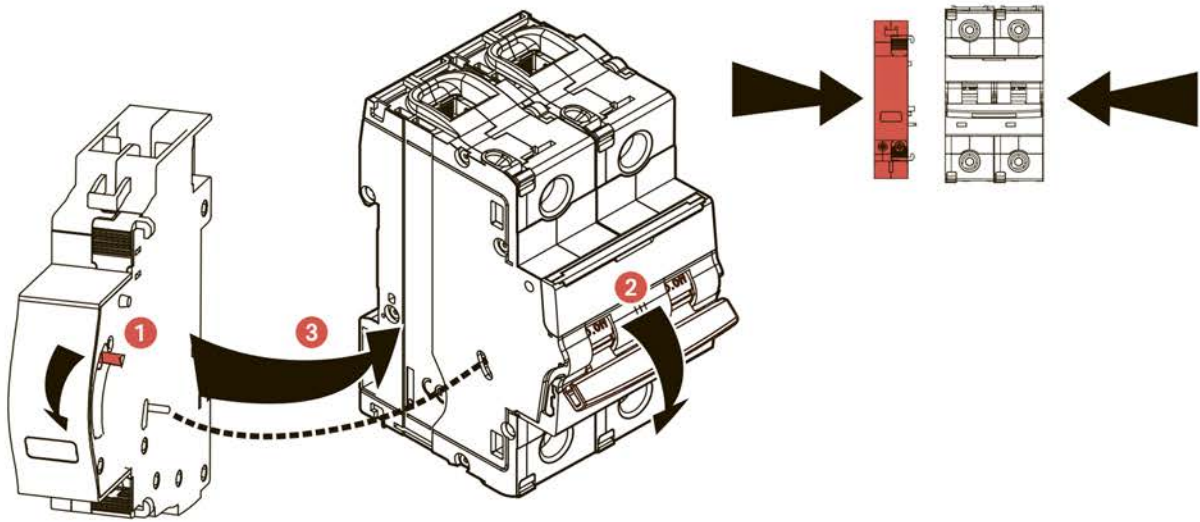

- 4 062 76
- 4 062 78
- 4 062 80
- 4 062 82
- 4 062 84
- 4 062 86
- 4 062 87

- 4 062 50
- 4 062 52
- 4 062 56
- 4 062 58
- 4 062 60
- 4 062 62
- 4 062 64
- 4 062 66

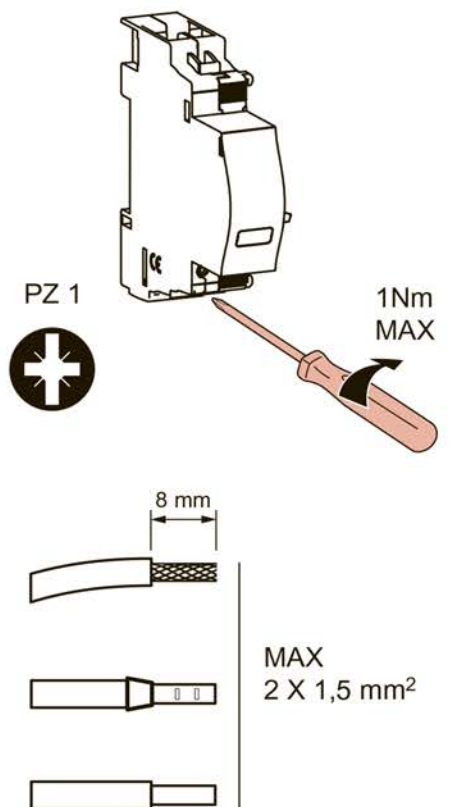
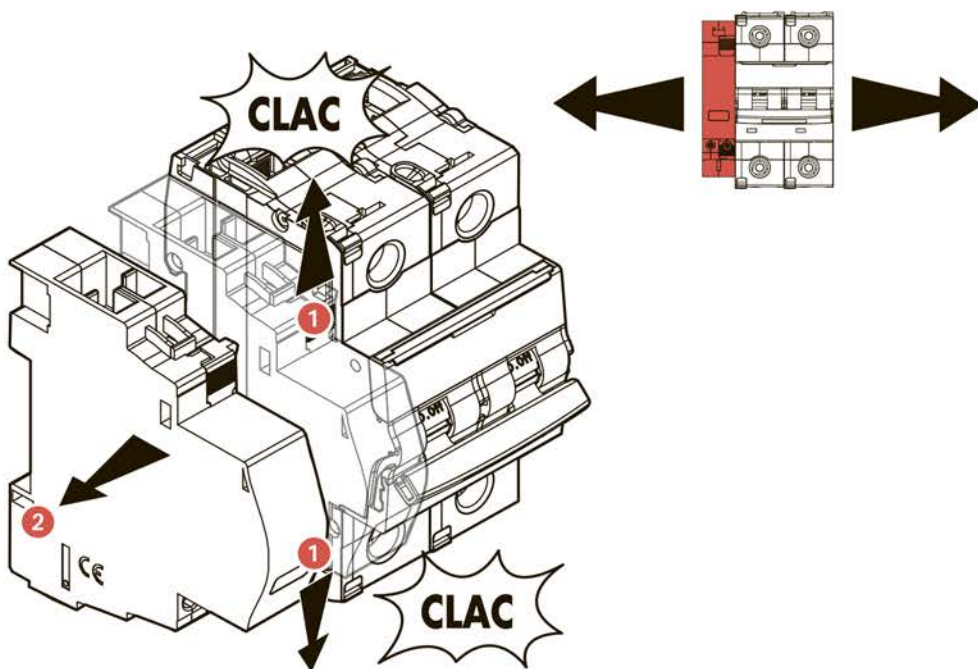

				4 062 .. 50 / 52 / 56 / 58 / 60 / 62 / 66 / 76 / 78 / 80 / 82 / 84 / 86 / 87
		4 062 .. 50 / 52 / 56 / 58 / 60 / 62 / 76 / 78 / 80 / 82 / 84 / 86 / 87	4 062 .. 50 / 52 / 56 / 58 / 60 / 62	
		4 062 .. 50 / 52 / 56 / 58 / 60 / 62 / 64 / 66 / 76 / 78 / 80 / 82 / 84 / 86 / 87	4 062 .. 64 / 66	
	4 062 .. 76 / 78 / 80 / 82 / 84 / 86 / 87	4 062 .. 50 / 52 / 56 / 58 / 60 / 62	4 062 .. 50 / 52 / 56 / 58 / 60 / 62	
		4 062 .. 50 / 52 / 56 / 58 / 60 / 62 / 64 / 66	4 062 .. 64 / 66	

				4 062 .. 50 / 52 / 56 / 58 / 60 / 62 / 66 / 76 / 78 / 80 / 82 / 84 / 86 / 87
		4 062 .. 50 / 52 / 56 / 58 / 60 / 62	4 062 .. 50 / 52 / 56 / 58 / 60 / 62	
		4 062 .. 50 / 52 / 56 / 58 / 60 / 62 / 64 / 66 / 76 / 78 / 80 / 82 / 84 / 86 / 87	4 062 .. 64 / 66	
	4 062 .. 76 / 78 / 80 / 82 / 84 / 86 / 87	4 062 .. 64 / 66	4 062 .. 64 / 66	

Ne pas respecter strictement les conditions d'installation et d'utilisation peut entraîner des risques de choc électrique ou d'incendie.

Door de installatie- en gebruiksvoorwaarden niet strikt na te leven, kan er gevaar voor elektrische schokken of brand ontstaan.

The instructions for installation and use must be strictly observed in order to avoid the risk of electric shock or fire.

Bei Nichtbeachtung der Einbau- und Nutzungsvorschriften besteht Stromschlag- bzw. Brandgefahr.

El no cumplimiento estricto de las instrucciones de instalación y uso puede implicar riesgos de choque eléctrico o incendio.

Il non rispetto alla lettera delle condizioni d'installazione e di utilizzo può generare rischi di scariche elettriche o di incendio.

Não respeitar estritamente as condições de instalação e de utilização poderá provocar riscos de choque eléctrico ou de incêndio.

Η μη αυστηρή τήρηση των συνθηκών εγκατάστασης και χρήσης μπορεί να επιφέρει κινδύνους ηλεκτροπληξίας ή πυρκαγιάς.

Несоблюдение правил монтажа и эксплуатации может повлечь за собой риск поражения электрическим током или возникновения пожара.

Niezastosowanie się ściśle do warunków instalacji i użytkowania może grozić porażeniem prądem lub pożarem.

Yerleşirme ve kullanim koşullarına uyulmaması elektrik çarpması veya yangın risklerine yol açabilir.

A beszerelési és használati feltételek szigorú betartásának elmulasztása áramütés vagy tűz kockázatával jár.

Jos et noudata tarkasti asennus- ja käyttöohjeita, voit aiheuttaa sähköiskun vaaran tai tulipalon.

FR LU BE CH

NL BE

GB IE

DE AT LI CH

ES

IT CH

PT

GR CY

RU

PL

TR CY

HU

FI

Om installationsvilkoren inte uppfylls strikt, föreligger risk för elchocker eller brand.

Nedodrženi stanovených podmínek instalace a používání může vést k rizikům zasažení elektrickým proudem nebo požáru.

V prípade nedodržania presných podmienok týkajúcich sa inštalácie a používania hrozí nízko úrazu elektrickým prúdom alebo vzniku požiaru.

Neupoštevanje vseh pogojev instalacije in uporabe lahko povzroči nevarnost električnega udara ali požara.

Hvis installations- og brugsbetingelserne ikke strengt overholdes, kan det medføre risiko for elektrisk stød eller brand.

Kui paigaldamis- ja kasutustingimusi ei järgita rangelt, võib see kaasa tuua elektrišoki või tulekahjuohtu.

Precizni neievėrojot uzstādīšanas un lietošanas noteikumus, pieaug elektriskās strāvas trieciena vai ugunsgrēka iespējamība.

Tiksliai nesilaikant instaliavimo ir naudojimo sąlygų gali kilti trumpojo elektros jungimo arba gaisro pavojus.

Manglende overhold av installasjons- og brugsbetingelsene kan føre til elektrisk støt eller brand.

Ef skilyrðum um uppsetningu og notkun er ekki vandlega fylgt kann slíkt að valda hættu á rafstöð eða eldsvoða.

Nerespectarea strictă a condițiilor de instalare și utilizare poate genera riscuri de șocuri electrice sau incendiu.

Неспазването стриктно на указанията за съгласяване и използване може да доведе до риск от токов удар или пожар.

SE

CZ

SK

SI

DK

EE

LV

LT

NO

IS

RO

BG

